



## Macalloy Tension Structures

Macalloy Tension Rods

Macalloy Compression Struts

Macalloy Stainless Cables

Macalloy Connection Solutions

Macalloy Site Services



For Tension Rod System only



ETA 17/0849

**EXPERIENCE**

**INNOVATION**

**QUALITY**



With innovation at the heart of our company ethos, Macalloy has been developing new systems and technologies in Tensile Structures since the early 1980's. Macalloy is a proven market leader in the design, manufacture and supply of threaded bar systems. Macalloy has experience in liaising with world renowned specifiers and contractors for the development of some truly unique and pioneering structures.

Macalloy's Tension Structures range is 9001 accredited and is approved with European Technical Approval – ETA - 17/0849, providing the CE certification, alongside other globally recognised certifications i.e. FPC Certificate

- FPC Certificate - 0836 - CPR - 16/F354
- BSEN 1090 - 1:2009 - Execution Class 3 - 0836 - CPR - 17/F381
- ETA - 17/0849
- BSEN ISO 9001: 2008-1055

Certificates are available on request.



- 4**      **Tension Rods**
- 8**      **Adjustable Compression Struts**
- 9**      **Macalloy CHS Fork End**
- 10**     **Stainless Cables**
- 12**     **Connection Solutions**
- 13**     **Component Dimensions**
- 14**     **Gusset Plates**
- 15**     **Fork Alignment & Site Services**

Table 1 - Material Properties

Product name	Material	Minimum Yield Stress N/mm <sup>2</sup>	Min. Breaking Stress N/mm <sup>2</sup>	Min. Elongation %	Min. Charpy Impact Value J@ -20°C	Nominal Youngs Modulus kN/mm <sup>2</sup>
Macalloy 460	Carbon Steel	460	610	19	27	205
Macalloy S460	Stainless Steel	460	610	15	27	205
Macalloy 520	Carbon Steel	520	690	19	27	205
Macalloy S520	Stainless Steel	520	690	15	27	205

Table 2 - Tendon Capacities for Carbon and Stainless Macalloy 460

Thread	Units	M10	M12	M16	M20	M24	M30	M36	M42	M48	M56	M64	M76	M85	M90	M100	M105
Nominal Bar Dia.	mm	10	11	15	19	22	28	34	39	45	52	60	72	82	87	97	102
Min. Yield Load	kN	25	36	69	108	156	249	364	501	660	912	1204	1756	2239	2533	3172	3520
Min. Break Load	kN	33	48	91	143	207	330	483	665	875	1209	1596	2329	2969	3358	4206	4667
Design Resistance to EC3 N <sub>R,d</sub>	kN	24	35	66	103	149	238	348	479	630	870	1149	1677	2138	2418	3029	3360
Nominal Bar Weight	(kg/m)	0.5	0.75	1.4	2.2	3.0	4.8	7.1	9.4	12.5	16.7	22.2	32	41.5	46.7	58	64.1

Table 3 - Tendon Capacities for Carbon and Stainless Macalloy 520

Thread	Units	M10	M12	M16	M20	M24	M30	M36	M42	M48	M56	M64	M76	M85	M90	M100	M105
Nominal Bar Dia.	mm	10	11	15	19	22	28	34	39	45	52	60	72	82	87	97	102
Min. Yield Load	kN	28	41	77	122	176	284	411	566	746	1030	1360	1985	2531	2862	3585	3979
Min. Break Load	kN	35	52	98	155	223	360	522	719	946	1308	1727	2520	3212	3633	4551	5279
Design Resistance to EC3 N <sub>R,d</sub>	kN	26	38	71	112	161	257	376	518	682	942	1244	1814	2313	2616	3277	3801
Nominal Bar Weight	(kg/m)	0.5	0.75	1.4	2.2	3	4.8	7.1	9.4	12.5	16.7	22.2	32	41.5	46.7	58	64.1

M85 to M105 in stainless is not covered by an ETA but is available by special request.

Table 4 - Maximum Length of Individual Bar Lengths

Diameter	Stainless Steel	Carbon	Galvanised
M10 - M16	6.0m	11.8m	6.0m
M20 - M30	6.0m	11.8m	8.0m
M36 - M105	6.0m	11.8m	11.8m

Longer lengths can be supplied as made to order if required

M105 Carbon is not covered by an ETA

## Corrosion Protection

Carbon steel tension bars can be supplied primed ready for an appropriate paint covering or galvanised. Galvanising can be applied prior to, or after, bar threading as required. Please note that all standard carbon Macalloy fittings (forks, pins and lockcovers etc.) are provided with a hot dipped galvanised coating in accordance with BS EN 1461: 2009

## Final Assembly Example

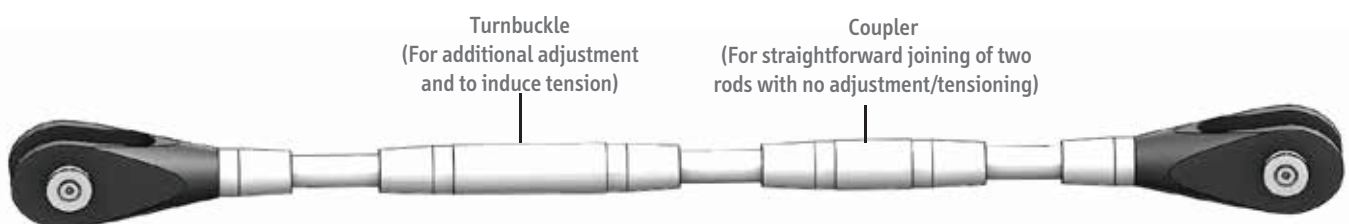

## Fork Adjustment and Set Up Points

Fork Adjustment – M10 to M56: +/- ½ thread diameter in each fork end.

Fork Adjustment – M64 to M105: +/- 25 mm in each fork end.

Set-Up Point – M10 to M56: 1 ½ x thread diameter in each fork end.

Set-Up Point – M64 to M105: 1 x thread diameter plus 25mm in each fork end.

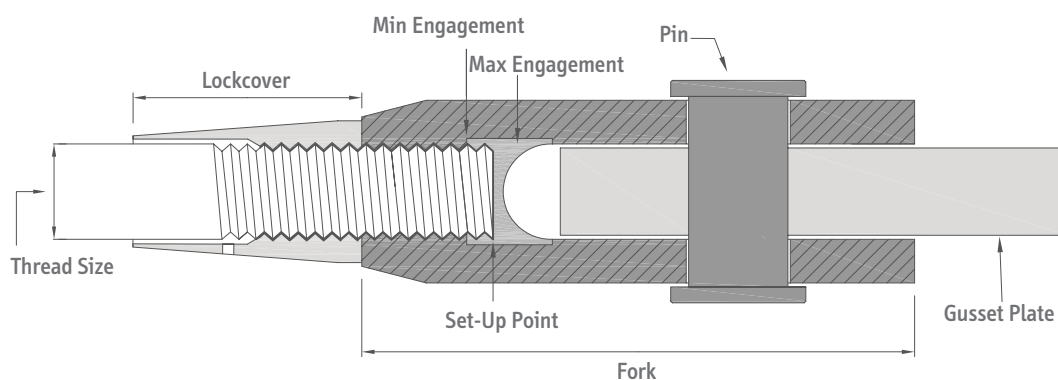

## Turnbuckle Adjustment and Set Up Points

Turnbuckle Adjustment – M10 to M24: +/- 25mm.

Turnbuckle Adjustment – M30 to M105: +/- 50mm.

Set-Up Point – M10 to M24: 1 x thread diameter +12.5mm in each end of the turnbuckle.

Set-Up Point – M30 to M105: 1 x thread diameter + 25mm in each end of the turnbuckle.

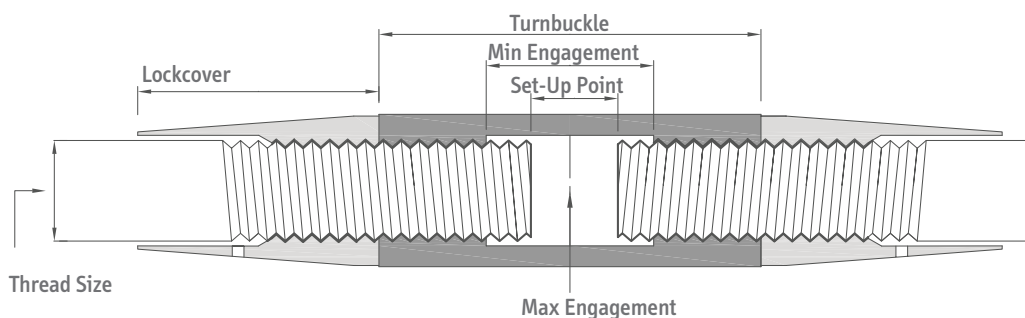

Renault Building, Swindon, UK  
 Architect – Foster Associates  
 Contractor – Tubeworkers  
 Engineer – Arup

## Assembly and Installation

For both pre-assembled and non-assembled tendons please follow the assembly and installation instructions to ensure correct set up points and thread engagement.

- 1 Note the thread direction of each bar end.



- 2 Screw tapered lockcovers on to the bar as far as thread allows with taper pointing away from fork, coupler or turnbuckle. Ensure correct lockcover is used for fork or turnbuckle.



- 3 Screw forks, turnbuckles and couplers on to bars noting set up points on page 5. Couplers should be fully engaged.

- 4 Position bar in place and secure with pins.



- 5 Where no turnbuckle is used, turn the bar to induce the load/adjustment required.

- 6 Where a turnbuckle is used turn the turnbuckle to induce the load/adjustment required.

- 7 Screw lockcovers back against forks/couplers and turnbuckles.



- 8 Seal as per fork and lock diagram on page 7.

- 9 Assembly and installation is complete.

To ensure full strength of threaded joints a minimum of 1 x thread diameter should be engaged in fork/turnbuckle joints.

Where large loads need to be induced in a tension bar the Macalloy TechnoTensioner can be used. See page 7 for more information.

Spanner flats available on request on bars and turnbuckles, please specify at time of order.

## TechnoTensioner

The Macalloy TechnoTensioner allows you to induce an accurate load into Macalloy tendons where a turnbuckle is used. The Macalloy TechnoTensioner works by gripping the tension bar on either side of the turnbuckle and pulling the bars together into tension thus loosening the turnbuckle. The turnbuckle can then be tightened with a strap, chain or stilson wrench.

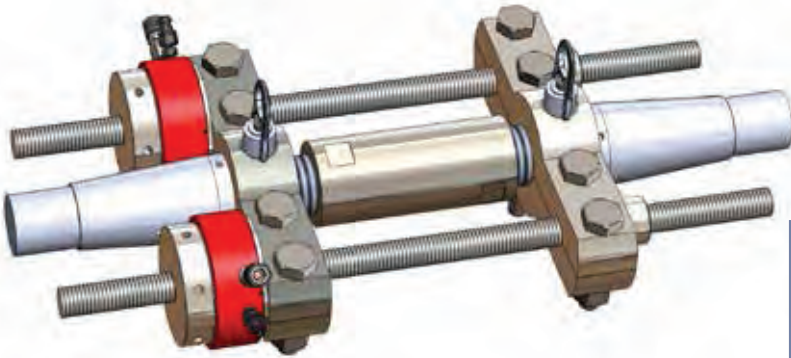

## Fork and Lock Cover Sealing

Recommended for use with all finishes to protect against vibration and corrosion. The same method should be applied whether used with a fork, coupler or turnbuckle.

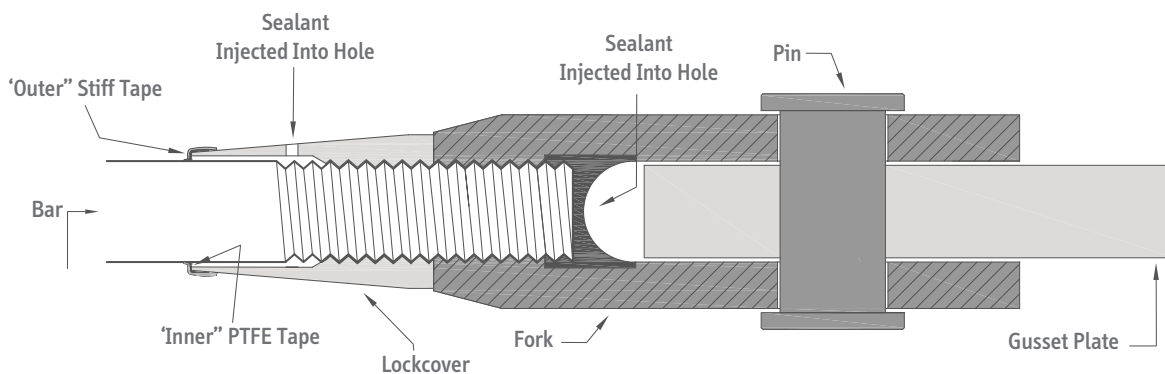

Fork and Lockcover sealing method statements are available on request. If no lock cover is used, contact Macalloy for sealing methods.

Table 5: Capacity and Lengths of Architectural and Standard Compression Struts

System Ref		M12	M16	M20	M24	M30	M36	M42	M48	M56	M64	M76	M85	M90	M100
Maximum compressive capacity to EN1993	kN	14.0	28.1	44.7	69.3	121.6	189.6	274.0	369.7	530.0	728.7	1063.9	1395.3	1588.6	2031.3
Maximum pin to pin length on EN1993 standard*	mm	2369	2663	2671	3105	3357	3367	4498	6397	7097	7420	8188	9323	10291	11679
Carbon CHS OD	mm	33.7	42.4	48.3	60.3	76.1	88.9	114.3	139.7	168.3	193.7	219.1	244.5	273	323.9
Carbon CHS Wall Thickness	mm	4	5	5	5	5	5	6.3	10	10	10	12.5	16	16	16
Stainless CHS OD	mm	33.40	42.16	48.30	60.33	73.03				Contact Macalloy for details					
Stainless CHS Wall thickness	mm	4.50	4.85	5.08	5.08	5.16				Contact Macalloy for details					

\*Maximum lengths are based on carbon steel strut taking compressive capacity. For lower compressive loads longer lengths can be used.

Alternative wall thicknesses are available. Contact Macalloy for details regarding maximum length of stainless steel struts.

## Compression Strut Examples



Architectural Compression Strut



Standard Compression Strut

## Fork Adjustment and Set Up

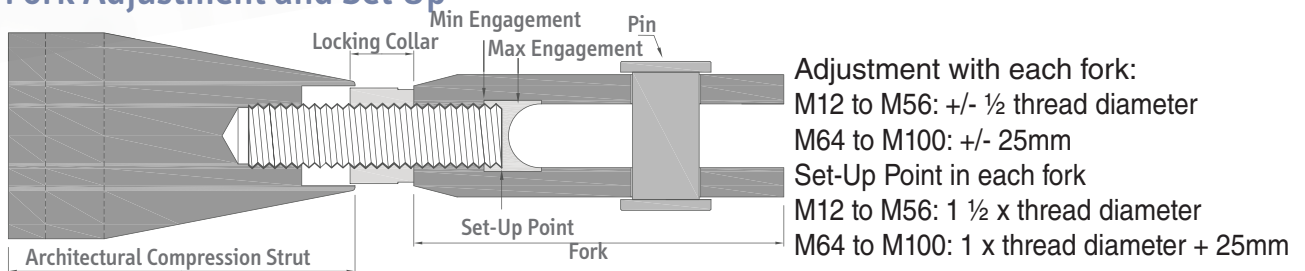

## Corrosion Protection

Compression Struts can be supplied galvanised, or in stainless steel.

## Assembly and Installation

1 Remove pins using an allen key, position the strut in place and secure with pins, tightening using an allen key.



2 Screw the locking collar in to the strut so only a small part of the locking collar is left visible, then turn the strut to the required position.



3 Screw the locking collar back against the fork. All the thread should be covered. The forks should be sealed as per the diagram on page 7.





**Table 6: Capacity of Macalloy CHS Fork Ends**

Macalloy Product Ref	Units	CSF 12	CSF 16	CSF 20	CSF 24	CSF 30	CSF 36	CSF 42	CSF 48	CSF 56	CSF 64	CSF 76	CSF 85	CSF 90	CSF 100	
CHS Size to fit	Outer Diameter	mm	33.7	42.4	48.3	60.3	76.1	88.9	114.3	139.7	168.3	193.7	219.1	244.5	273	323.9
	Wall thickness	mm	4.0	5.0	5.0	5.0	5.0	5.0	6.3	10.0	10.0	10.0	12.5	16.0	16.0	16.0
Compressive Capacity to EN 1993	kn	52	99	122	174	272	374	534	735	1048	1437	2127	2723	3110	3686	
Equivalent Macalloy Fork Size		M12	M16	M20	M24	M30	M36	M42	M48	M56	M64	M76	M85	M90	M100	
Gusset Plate Thickness	mm	10	12	15	20	22	30	35	40	45	55	70	70	80	85	
Weight	kg	0.25	0.51	1.0	1.4	2.4	3.7	6.2	10.8	15.8	20.5	40.3	59.3	74.0	100.0	

## Macalloy CHS Fork End



### Corrosion Protection

Can be galvanised and or painted and supplied in stainless steel to special order.

### Assembly and Installation

**1** Insert Macalloy CHS Fork End into CHS / tube, ensuring it is fully inserted and that the forks are perpendicular to each other.



**2** Weld directly to CHS with full penetration butt weld and clean weld as required (ensuring forks are perpendicular to each other)



**3** Position complete strut in place and secure using pins.



Architectural pins can be supplied by Macalloy. Please refer to table number 12 on page 13 for further information.

**Table 7: Macalloy CHS Fork End Dimensions**

System Ref	Product Ref.	Units	CSF 12	CSF 16	CSF 20	CSF 24	CSF 30	CSF 36	CSF 42	CSF 48	CSF 56	CSF 64	CSF 76	CSF 85	CSF 90	CSF 100
Fixed End Compression Strut fork	A	mm	75	95	109	130	161	185	218	255	303	340	398	462	495	574
	G (min.)	mm	13	16	20	25	30	35	40	45	49.5	59.5	76	76	86	91
	C Dia.	mm	33.7	42.4	48.3	60.3	76.1	88.9	114.3	139.7	168.3	193.7	219.1	244.5	273	323.9
	D Dia.	mm	13	17	21.5	25.5	31.5	37.5	43.5	49.5	57.5	65.5	78.5	91.5	96.5	111.5
	E	mm	22	29	34	42	52	61	70	81	97	111	132	153	162	189
	Y	mm	22	28	37	44	53	64	75	87	97.5	115.5	146	153	169	174
	H	mm	34	45	53	64	81	93	109	123	147	169	201	236	248	289

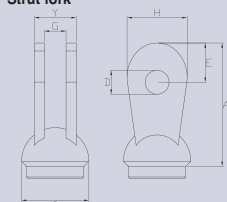





Table 8: Minimum Break Loads for Stainless Cables

Cable Dia.	mm	4	6	8	10	12	14	16	19	22	26
Macalloy Fork Size		M10	M10	M12	M16	M20	M24	M24	M30	M30	M36
7 x 19 Strand	kN	8.9	20.0	35.6	55.6	80.0	109.0	143.1	-	-	-
1 x 19 Strand	kN	12.6	28.2	45.5	71.1	102.0	139.0	182.0*	212.0*	285.0*	398.0*
Compact Strand	kN	17.4	34.8	60.3	95.0	141.2	189.2	251.0	-	-	-

7 x 19 Strand		Most Flexible	Lowest Break Load	
1 x 19 Strand		Rigid Cable	High Break Load	Low Stretch Characteristics
Compact Strand		Most Rigid	Low Stretch	Highest Tensile Strength

Stainless steel cable will begin to distort at around 50% of its breaking load. For this reason it is recommended to apply a factor of safety of 2 and not to load the cables to more than 50% of their breaking loads.

\*1 x 37 or 1 x 61 may also be offered.

## SC460 Cable Systems - SC460 Swaged Adjustable Fork



## SC460 Cable Systems - SC460 Swaged Fork / Tensioner

### Assembly and Installation

- 1 Remove pins using supplied allen key and screw lockcovers away from tensioners as far as the thread will allow.



- 2 Position cable in place and secure with pins, tightening with supplied allen key. For Swaged fork tensioning use open ended spanner on each adjuster and simultaneously turn each one to induce load / adjustment.



- 3 Swaged Tensioner and Inline Tensioner Adjustment – Turn tensioner using open ended spanner until correct level of adjustment tension is achieved. Then screw lockcovers back against the tensioners.



Where large loads need to be induced in a cable, a version of the Macalloy TechnoTensioner can be used. Refer to page 7 for further information.

## Cable stretch

Cables undergo an initial, permanent stretch. This can be between 0.10% and 0.75% dependant on the loading and type of cable. Further elastic stretch will then be proportional to the load applied and cable used. Elastic stretch can be calculated using the following formula:

$$d = \frac{\text{Load (kN)} \times \text{Length (mm)}}{E \text{ (kN/mm}^2\text{)} \times \text{Cross Sectional Area (mm}^2\text{)}}$$

Where E =

7 x 19 Strand	85 kN/mm <sup>2</sup>
1 x 19 Strand	107 kN/mm <sup>2</sup>
Compact Strand	133 kN/mm <sup>2</sup>

All cables are supplied non pre-stretched, if pre-stretched cables are required please request at time of the enquiry or order.

## Fork Adjustments

Table 9: Adjustable Swaged Fork Adjustment

Cable Dia.	units	4	6	8	10	12	14	16	19	22	26	28
Fork Adjustment '+'	mm	9	14	16	21	24	30	30	38	38	45	45
Fork Adjustment '-'	mm	18	16	32	43	48	62	62	76	76	90	90
Set-Up Point	mm	18	28	32	42	48	60	60	76	76	90	90

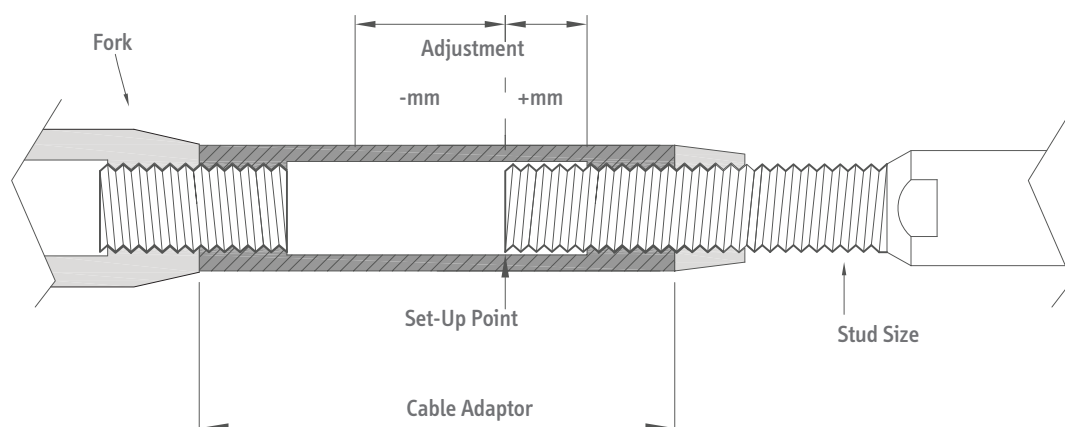
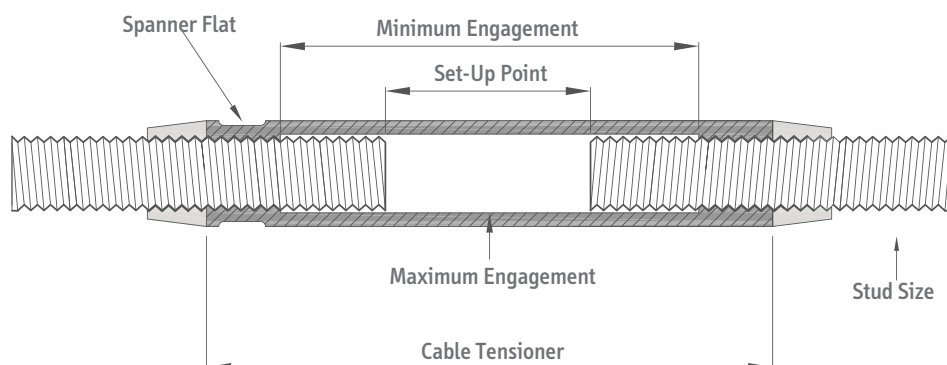

Table 10: Swaged Tensioner and Inline Tensioner Adjustment

Cable Dia.	units	4	6	8	10	12	14	16	19	22	26	28
Swaged Tensioner '+/-'	mm	43	43	58	73	87	106	126	135	164	164	164
Set-Up Point	mm	28	28	32	42	50	70	70	91	91	94	94





Disc Connection



Cross Coupler



Turnbuckle with Fin Plate

Table 11 – Disc Connection

Connection Disc	D/10	D/12	D/16	D/20	D/24	D/30	D/36	D/42	D/48	D/56
<b>System Size</b>	M10	M12	M16	M20	M24	M30	M36	M42	M48	M56
<b>ØD</b>	130	164	218	248	294.8	386	444	502	572	694
<b>ØI</b>	96	120	160	180	210	280	320	360	410	500
<b>T</b>	10	10	12	15	20	22	30	35	40	45
<b>ØP</b>	11.5	13	17	21.5	25.5	31.5	37.5	43.5	49.5	57.5
<b>ØH (optional)</b>	50	70	90	105	115	160	185	205	235	290

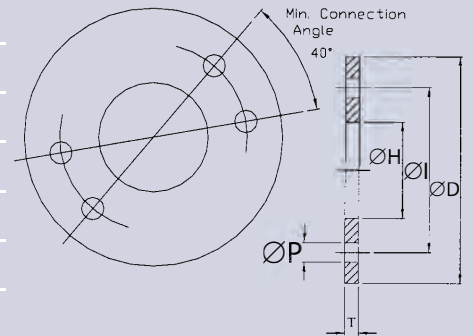

Table 12 – Cross Coupler

Cross-Coupler	CC10	CC12	CC16	CC20	CC24	CC30	CC36	CC42	CC48	CC56	CC64
<b>System Size</b>	M10	M12	M16	M20	M24	M30	M36	M42	M48	M56	M64
<b>A</b>	73	82	105	128	148	183	217	249	283	328	376
<b>B</b>	47	52	67	82	94	117	139	159	181	210	242
<b>C</b>	12	14	18	22	26	32	38	44	50	58	66
<b>ØD</b>	19	25	29	35	43	52	62	72	82	96	110
<b>Lock Cover</b>	LCC10	LCC12	LCC16	LCC20	LCC24	LCC30	LCC36	LCC42	LCC48	LCC56	LCC64
<b>System Size</b>	M10	M12	M16	M20	M24	M30	M36	M42	M48	M56	M64
<b>E</b>	29	31	37	43	74	105	111	117	123	136	144
<b>ØF</b>	18.5	24	28	34	42	51	61	71	81	95	109

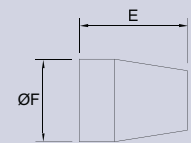
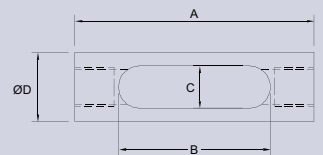
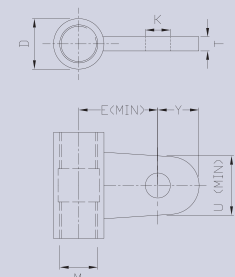

Table 13 – Turnbuckle with Fin Plate

Thread M	M10	M12	M16	M20	M24	M30	M36	M42	M48	M56	M64	M76	M85	M90	M100
<b>Y (mm)</b>	18	22	30	37	43	56	64	74	84	101	112	132	160	166	196
<b>U (min) (mm)</b>	28	34	48	60	68	90	103	118	135	163	180	211	259	266	317
<b>E (min) (mm)</b>	28	32	39	44	52	63	71	80	91	107	121	142	163	172	198
<b>D (mm)</b>	17	20	26	32	38	47	56	66	75	87	99	119	135	143	160
<b>K (mm)</b>	11.5	13	17	21.4	25.5	31.5	37.5	43.5	49.5	57.5	65.5	78.5	91.5	96.5	111.5
<b>T (mm)</b>	10	10	12	15	20	22	30	35	40	45	55	70	70	80	85



### Bespoke connection

Bespoke connection pieces including personalisation are also available. Please contact Macalloy for further details.

**Table 14 – Component Dimensions**

Thread	Units	M10	M12	M16	M20	M24	M30	M36	M42	M48	M56	M64	M76	M85	M90	M100
<b>Fork Ref.</b>		FA/10	FA/12	FA/16	FA/20	FA/24	FA/30	FA/36	FA/42	FA/48	FA/56	FA/64	FA/76	FA/85	FA/90	FA/100
<b>A</b>	mm	63.0	75.0	99.0	122.0	148.0	178.0	204.0	232.0	266.0	314.0	348.0	410.0	459.0	489.0	555.0
<b>G</b>	mm	11.0	12.0	15.0	19.0	24.0	26.0	34.0	39.0	44.0	49.0	59.0	76.0	78.0	86.0	91.0
<b>C</b>	mm	17.0	19.0	25.0	29.0	35.0	44.0	52.0	60.0	69.0	80.0	91.0	108.0	121.0	129.0	143.0
<b>D</b>	mm	11.5	13.0	17.0	21.4	25.5	31.5	37.5	43.5	49.5	57.5	65.5	78.5	91.5	96.5	111.5
<b>E</b>	mm	18.0	22.0	29.0	34.0	42.0	53.0	61.0	70.0	81.0	97.0	111.0	132.0	153.0	162.0	188.0
<b>Y</b>	mm	20.0	22.0	28.0	37.0	44.0	50.0	64.0	75.0	87.0	97.0	115.0	146.0	154.0	169.0	174.0
<b>H</b>	mm	30.0	34.0	45.0	53.0	64.0	81.0	93.0	109.0	123.0	147.0	169.0	201.0	236.0	248.0	289.0
<b>Spade ref.</b>		SA/10	SA/12	SA/16	SA/20	SA/24	SA/30	SA/36	SA/42	SA/48	SA/56	SA/64	SA/76	SA/85	SA/90	SA/100
<b>B</b>	mm	78.0	92.0	118.0	147.0	174.0	213.0	249.0	284.0	321.0	364.0	408.0	471.0	524.0	555.0	625.0
<b>T</b>	mm	8.0	9.0	12.0	15.0	20.0	22.0	30.0	35.0	40.0	45.0	55.0	70.0	72.0	80.0	85.0
<b>Architectural Pin Ref.</b>		PA/10	PA/12	PA/16	PA/20	PA/24	PA/30	PA/36	PA/42	PA/48	PA/56	PA/64	PA/76	PA/85	PA/90	PA/100
<b>P Dia.</b>	mm	10.5	12.0	16.0	20.0	24.0	29.0	35.0	41.0	47.0	55.0	63.0	76.0	89.0	93.0	108.0
<b>L</b>	mm	22.0	24.0	30.0	39.0	46.0	52.0	66.0	78.0	91.0	100.0	120.0	151.0	155.0	175.0	180.0
<b>Hex Nuts Units</b>		M10	M12	M16	M20	M24	M30	M36	M42	M48	M56	M64	M76	M85	M90	M100
<b>E</b>	mm	18.9	21.9	26.75	32.95	39.55	50.85	60.79	71.3	82.6	95.07	106.37	123.32	133.11	145.77	162.72
<b>H</b>	mm	8.0	10.0	13.0	16.0	19.0	24.0	29.0	34.0	38.0	45.0	51.0	61.0	68.0	72.0	80.0
<b>S</b>	mm	17.0	19.0	24.0	30.0	36.0	46.0	55.0	65.0	75.0	85.0	95.0	110.0	120.0	130.0	145.0
<b>Pitch</b>		1.5	1.75	2.0	2.5	3.0	3.5	4.0	4.5	5.0	5.5	6.0	6.0	6.0	6.0	6.0
<b>Turnbuckle Ref.</b>		TA/10	TA/12	TA/16	TA/20	TA/24	TA/30	TA/36	TA/42	TA/48	TA/56	TA/64	TA/76	TA/85	TA/90	TA/100
<b>ØD</b>	mm	17.0	19.0	25.0	29.0	35.0	43.0	52.0	60.0	68.0	80.0	91.0	108.0	121.0	129.0	143.0
<b>C</b>	mm	50.0	50.0	50.0	50.0	50.0	100.0	100.0	100.0	100.0	100.0	100.0	100.0	100.0	100.0	100.0
<b>L</b>	mm	74.0	78.0	86.0	90.0	98.0	160.0	172.0	184.0	196.0	212.0	228.0	252.0	270.0	280.0	300.0
<b>Coupler Ref.</b>		CA/10	CA/12	CA/16	CA/20	CA/24	CA/30	CA/36	CA/42	CA/48	CA/56	CA/64	CA/76	CA/85	CA/90	CA/100
<b>ØD</b>	mm	17.0	19.0	25.0	29.0	35.0	43.0	52.0	60.0	68.0	80.0	91.0	108.0	121.0	129.0	143.0
<b>L</b>	mm	25.0	29.0	37.0	45.0	53.0	65.0	77.0	89.0	101.0	117.0	133.0	157.0	175.0	185.0	205.0
<b>Fork &amp; Coupler Lockcovers</b>		LCF/10	LCF/12	LCF/16	LCF/20	LC/24	LC/30	LC/36	LC/42	LC/48	LC/56	LC/64	LC/76	LC/85	LC/90	LC/100
<b>X Dia.</b>	mm	16.5	18.5	24	28	34	42	51	59	67	79	90	107	120	128	142
<b>N</b>	mm	29	31	37	43	74	105	111	117	123	136	144	156	165	170	180
<b>Universal Lockcovers</b>		LCT/10	LCT/12	LCT/16	LCT/20	LCT/24	LCT/30	LCT/36	LCT/42	LCT/48	LCT/56	LCT/64	LCT/76	LCT/85	LCT/90	LCT/100
<b>X Dia.</b>	mm	16.5	18.5	24.0	28.0	34	42	51	59	67	79	90	107	120	128	142
<b>N</b>	mm	44.0	44.0	46.0	48.0	92	126	134	145	153	169	179	191	200	205	215

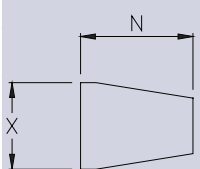
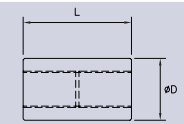
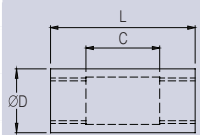
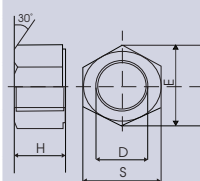
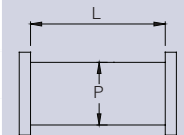
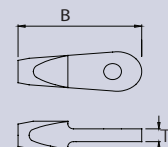
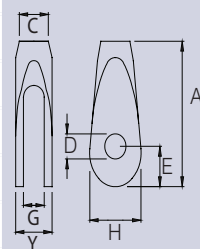

Lock covers for use with TechnoTensioner have a small groove that runs around the body to identify them. Unless requested, standard non-TechnoTensioner lock covers will be quoted and supplied.

Please note that all standard Macalloy fittings (forks, pins and lockcovers) are provided with a hot dipped galvanised coating in accordance with BS EN 1461: 2009

Gusset plates should be manufactured from material with a minimum strength of S355 JR to BS EN 10025 with the critical dimensions around the pin hole as per the tables below, noting the use of isolation when carbon gusset plates are used with stainless tendons.

**Table 15 - Macalloy Standard Gusset Plate Dimensions**

	M10	M12	M16	M20	M24	M30	M36	M42	M48	M56	M64	M76	M85	M90	M100	
<b>T (Thickness)</b>	mm	10	10	12	15	20	22	30	35	40	45	55	70	70	80	85
<b>D</b>	mm	11.5	13	17	21.5	25.5	31.5	37.5	43.5	49.5	57.5	65.5	78.5	91.5	96.5	111.5
<b>E</b>	mm	18	22	30	37	43	56	64	74	84	101	112	132	160	166	196
<b>H (min.)</b>	mm	28	34	48	60	68	90	103	118	135	163	180	211	259	266	317



**Table 16 - Macalloy Gusset Plate Dimensions when used with isolation**

	M10	M12	M16	M20	M24	M30	M36	M42	M48	M56	M64	M76	
<b>T (Thickness)</b>	mm	8	9	12	15	20	22	30	35	40	45	55	70
<b>D</b>	mm	15.5	17.0	21.0	25.5	30.0	36.0	42.0	48.0	55.5	63.5	72.5	85.5
<b>E</b>	mm	21	24	31	37	45	56	64	74	85	100	115	136
<b>H (min)</b>	mm	34	38	49	58	69	89	108	117	136	160	179	210

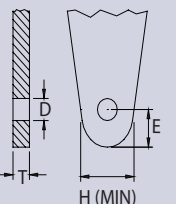

The above dimensions should be used when connecting stainless forks to a carbon steel connection plate. This then allows space for isolation sleeves and washers. If connecting to a stainless connection plate where no isolation is required, please use dimensions in table 13.

**Table 17 – Isolation Dimensions for Macalloy S460**

	M10	M12	M16	M20	M24	M30	M36	M42	M48	M56	M64	M76	
<b>Isolation Sleeve</b>	IS10	IS12	IS16	IS20	IS24	IS30	IS36	IS42	IS48	IS56	IS64	IS71	
<b>Length</b>	mm	9	10	13	16	21	23	31	36	41	46	55	71
<b>ID</b>	mm	11.5	13.0	17.0	21.0	25.0	31.0	37.0	43.0	49.0	57.0	64.5	77.5
<b>OD</b>	mm	14.5	16.0	20.0	24.5	29.0	35.0	41.0	47.0	54.0	62.0	71.0	84.0
<b>Isolation Washer</b>	IW10	IW12	IW16	IW20	IW24	IW30	IW36	IW42	IW48	IW56	IW64	IW76	
<b>D</b>	mm	0.5	0.5	0.5	1.0	1.0	1.0	1.0	1.0	1.0	1.0	1.0	
<b>OD</b>	mm	26	30	41	46	57	74	83	98	110	135	190	

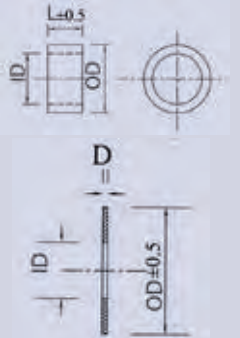

**Whitelee Wind Farm,**  
Eaglesham Moor, UK  
Architect – Hypostyle  
Contractor – Morrison Construction

## Fork / Gusset Plate Misalignment



Forks should be kept in plane and perpendicular to each other on all Macalloy Tension Structure Systems.



Use of horizontal gusset plates should be avoided to prevent loads in gusset plates due to bar weight.

Max = 0.5°



Standard Arrangement

Max = 5.90°



Additional misalignment with spherical bearing

The standard Macalloy fork allows for misalignment between gusset plates of up to 0.5 degrees. Where greater adjustment is required or there is potential movement exceeding 0.5 degrees, larger forks can be put on the bar or strut and a spherical bearing can be inserted providing up to 5.9 degrees of misalignment / movement.

## Macalloy Site Services

**Equipment Hire** – Macalloy Site services can provide a range of equipment to assist with the installation of tension bars including hydraulic jacks, Macalloy TechnoTensioner, strap and chain wrenches and strain gauges.

**Site support** – Macalloy site services personnel can provide on site support in the form of undertaking stressing, training local personnel and providing supervision.

## Bespoke Systems

Macalloy can supply a range of special items, including but not limited to:

- Higher strength tension bar – up to 690 N/mm<sup>2</sup> minimum yield strength
- Larger diameter tension bars
- Bespoke cast and fabricated connection pieces
- Spade Connections
- Oversized forks or spades on smaller diameter bars, cables or struts

## Engineering Support

Macalloy engineering team can provide support and advice on a range of issues including fire protection, thermal expansion, installation and stressing and managing misalignment and movement.

**Sky Walk, Czech Republic**  
Designer and main supplier Taros Nova  
architect: Fránek architects  
photo: Jakub skokan, Martin Tůma / BoysPlayNice



**Mbombela Stadium,**  
Nelspruit South Africa  
Client - Mbombela Local Municipality  
Structural Engineer - Mott MacDonald

**Troja Bridge, Czech Republic**  
Steel Work Designer - Excon Steel  
Main Contractor - Metrostav



This publication provides the technical details currently used by Macalloy in the manufacture of its components.  
The company reserves the right to amend technical details as and where necessary in line with its policy of continuous development.

**Macalloy**

Macalloy, Caxton Way, Dinnington

Sheffield S25 3QE, U.K.

+44 (0)1909 519200.

[www.macalloy.com](http://www.macalloy.com)

[sales@macalloy.com](mailto:sales@macalloy.com)

[technical@macalloy.com](mailto:technical@macalloy.com)

[siteservices@macalloy.com](mailto:siteservices@macalloy.com)

